

TYPE: BP16

BP16 Strain Gauge Pressure Transducer

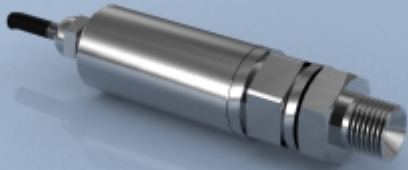

Description

The LCM Systems range of Pioden transducers has been widely used for many years. The BP16 range of pressure transducers combine the excellent performance of bonded foil strain gauge technology with a single piece stainless steel diaphragm construction. They provide a cost effective price/performance ratio and are suitable for use in many arduous measurement applications.

The BP16 construction makes it ideal for a wide range of applications, including hydraulic lifting, mobile hydraulic vehicles, portable test gear and air frame test rigs amongst others.

The most popular version of the BP16 is the integral cable version, which is supplied with a 2 metre PVC cable. An integral connector version is also available, as are versions with different cable lengths or different cable types.

The BP16 offers a variety of amplified outputs in the same packaging arrangement (a separate data sheet is available detailing these).

We can supply the BP16 on its own or integrated with any of the wide range of strain gauge based instrumentation available from LCM Systems.

Features

- Ranges from 100psig to 15,000psig
- Stainless steel diaphragm (single piece construction)
- 1/4" BSPP female pressure port (supplied as standard with bonded seal and 1/4" male pressure port adaptor)
- 1000ohm bonded foil strain gauge bridge resistance as standard (option of 350ohm bridge available)
- Amplified voltage output version (refer to BP16UVW data sheet)
- Amplified current output version (refer to BP16EF data sheet)

Specification

Pressure Range (psig)	100, 150, 200, 500, 1000, 2000, 3000, 5000, 10,000, 15,000
Over pressure range	150% with $\leq \pm 1\%$ calibration shift 125% with 15,000psi version
Burst pressure	400% (200% for 15,000psi version)
Output sensitivity	2mV/V nominally
Zero offset	$\leq \pm 4\%$ of full scale output (FSO)
Accuracy	$\leq \pm 0.1\%$ FSO ($\pm 0.7\%$ for 100-200psi versions)
Repeatability	$\leq \pm 0.1\%$ FSO
Bridge resistance	1000 Ω standard (350 Ω optional)
Insulation resistance	>1000M Ω @ 250vdc
Operating temperature range	-20 to +70°C
Compensated temperature range	-10 to +60°C
Zero temperature coefficient	$\leq \pm 0.03\%$ of FSO/°C ($\leq \pm 0.01\%$ FSO/°C optional)
Span temperature coefficient	$\leq \pm 0.03\%$ of FSO/°C ($\leq \pm 0.01\%$ FSO/°C optional)
Environmental protection level	IP66
Connection type	2 metre 4 core screened PUR cable or 4 pin Lumberg connector (c/w 5m PUR cable assembly)
Wiring connections	+ve supply: Red (Pin 1) -ve supply: Blue (Pin 2) +ve signal: Green (Pin 3) -ve signal: Yellow (Pin 4)

Typical Applications

- On-board vehicle weighing
- Earthmoving vehicle hydraulic system protection/weighing
- Portable hydraulic test sets
- Air frame test rigs
- Hydraulic system feedback control

Available Options

- Integral connector option
- Modified cable length/type options
- Amplified output options
- TEDS option (when used with TR150 handheld display)
- Other special versions available

LCM Systems Ltd

Unit 15, Newport Business Park
Barry Way, Newport
Isle of Wight PO30 5GY UK
Tel: +44 (0)1983 249264
Fax: +44 (0)1983 249266
sales@lcm systems.com
www.lcm systems.com

BP16 Strain Gauge Pressure Transducer

Dimensions

Integral Cable Version

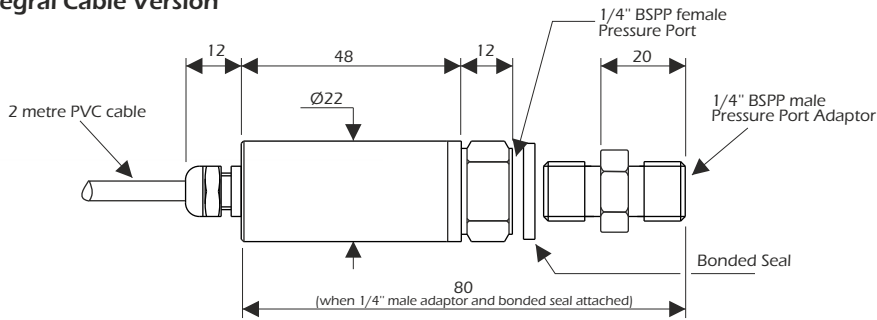

Integral Connector Version

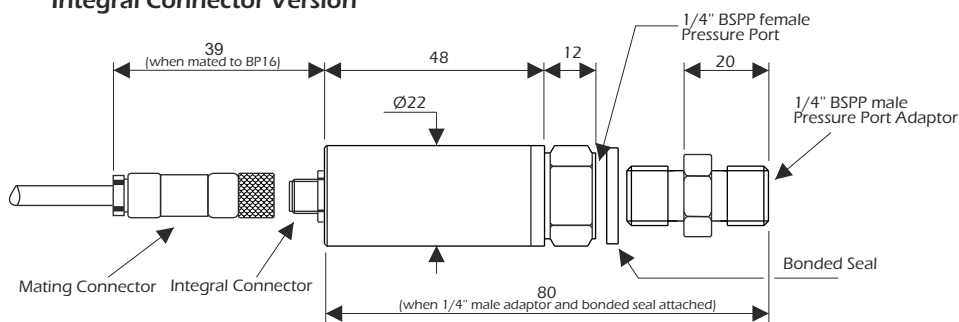

All dimensions are in mm

Rating (psi)	Weight (g)	Resolution (psi)
100	40	0.5
150	40	0.5
200	40	1
500	40	0.5
1000	40	1
2000	40	2
3000	40	2
5000	40	5
10000	40	10
15000	40	10



www.lcmsystems.com



SCIGATE AUTOMATION (S) PTE LTD

No.1 Bukit Batok Street 22 #01-01 Singapore 659592
 Tel: (65) 6561 0488 Fax: (65) 6562 0588
 Email: sales@scigate.com.sg Web: www.scigate.com.sg

Business Hours: Monday - Friday 8.30am - 6.15pm

Due to continual product development, LCM Systems Ltd reserves the right to alter product specifications without prior notice.

Issue No. 2

Issue date: 14/11/2016

APPROVED

(unapproved if printed)